

The installation pack will include sufficient brackets and screws for the fitting of your blinds.

IMPORTANT

Please read the child safety information attached to your blind.

Free Hang Blinds (Rectangular)

Top Fixing Brackets

Fix two brackets to the ceiling or lintel, using holes drilled at least 25mm (1”) from the wall or window frame and at least 70mm (2 ¾”) from each end of the blind. Any remaining brackets should be fixed equidistantly between these first two brackets.

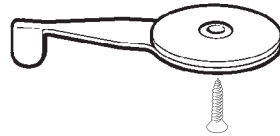

Face Fixing Brackets

Fix the brackets to the wall or window frame as closely as possible to the ceiling or lintel with the same spacing as recommended for top fixing brackets.

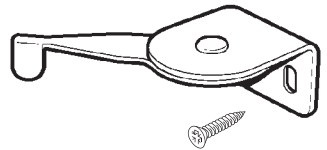

Side Fixing Brackets

Fix one bracket to the wall either side of the blind. Any remaining top fix brackets should be fixed so that the operation levers are spaced evenly between the end brackets.

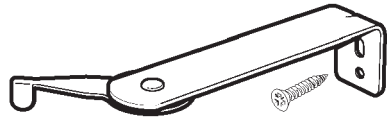

Fitting the Track

The blind must be fitted with the control cords at the front. Turn the levers on the brackets so that the two projections below the brackets line up with the slot in the top of the track. Locate these projections in the brackets into the track. Ensure that the internal track cords are clear of the brackets and turn the levers towards the centre of the blind to lock the headrail in place.

Operating your Free Hang Blinds

To lower the blind hold the control cord in a vertical position and pull it downwards slightly to release the cord locking mechanism. Keeping hold of the cord allow the blind to drop or unfurl slowly to the desired position. Pull the cord to the side of the blind to lock the mechanism then release the cord. To raise the blind pull the cord until the blind is at the required level and move the cord to the

Skylight Blinds (Rectangular)

N.B.The blind will be held together with elastic bands. These must **not** be moved until you have read these instructions.

Fitting the Brackets

Fit the brackets to the top and bottom of the window opening following the instructions for the free hang blinds. Brackets should be fixed level with the positions from which the blind measurements were taken.

Fitting the Tracks

Without removing the elastic bands fix the top rail to the brackets at the top of the window. Support the lower rail and remove the two outside elastic bands. Turn this lower rail so that the cords wrapped around it unwind. Maintain sufficient tension to ensure that the cords do not slip off the end of the rail and become entangled. When the cords are fully unwrapped remove any packing material from the lower rail, fit it to the locating brackets and remove the centre elastic band.

The friction cords, which are at the outside of the blind, are connected by an internal spring. They have been adjusted to the correct length during manufacture. Fitting the lower track into the brackets stretches this spring and firm pressure must be used to locate the track into the brackets. If, for any reason, the friction cords are too loose or too tight they can be adjusted easily. Release the rail at the bottom of the opening and undo the knot which joins one of the cords to the spring. Re-tie the knot in the position which allows the middle rail to move up and down easily and remain in any position to which it is set when the bottom track is replaced in its brackets

Tensioning the Nylon Fabric Supports

The ends of the Nylon Fabric Supports project from the bottom rail of the blind. Each one is fitted with a barrel clamp. After the blind has been fitted into the brackets tighten each Nylon Support by undoing the screw on the clamp and pulling the nylon until it is taut. Re-tighten the clamp screw taking care not to cut the nylon Support by over-tightening the screws. Push the clamp into the hole in the rail and continue until all the Nylon Supports have been tightened.

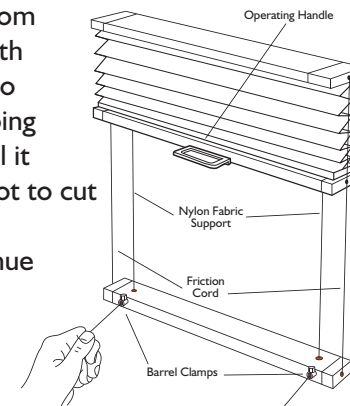

Skylight Blinds (Triangular)

Fitting the Brackets

Assemble the apex bracket as illustrated. To fit a blind inside a frame, mount the apex bracket as near as possible to the apex of the frame with the centre plate parallel to the base of the opening. Fix the remaining brackets to the base of the opening. One bracket should be fitted approximately 6” (150mm) from each corner and any remaining brackets fitted equidistantly between these two. To fit a blind outside of an opening the brackets must be fitted at the same levels, but at the appropriate distance from the frame.

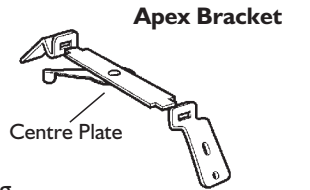

Fitting the Blind

The blind consists of one wide rail to be fixed at the base of the opening; one short rail to be fixed at the top of the opening and a second short rail, which slides between the two fixed rails, drawing the wood weave across the opening. The two fixed rails are connected by two friction cords, spaced approximately 3 ¼” (85mm) apart. They are also connected by a nylon guide which is in between the two friction cords. These friction cords will have been set to length during manufacture. However, they may require some adjustment during installation.

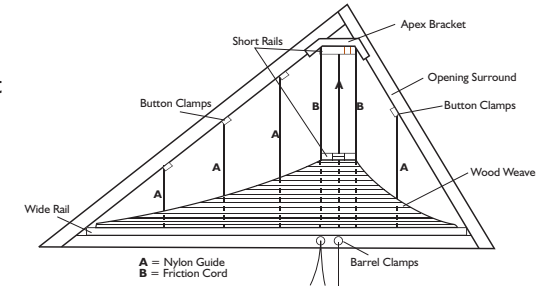

Unwind the cords from the wide rail of the blind. Fix this rail to the brackets at the base of the opening. Fix the Short Rail which is **not** attached to the wood weave to the apex bracket. There may be some difficulty experienced in attaching this short rail to the bracket if the friction cords are too short. At the wide, bottom rail there are two clamps (see illustration). One holds two cords and one holds one nylon support. Loosen the clamp which holds the **two** cords. Ensure that the short top rail is fitted into the apex bracket and adjust the tension in the two cords, so that the short middle rail moves up and down easily and remains in any position to which it is set.

Tighten the nylon guide which runs between the two tension cords following the instructions for rectangular blinds. Now tighten the remaining nylon guide cords. These are held in place by plastic button clamps which should be fitted to the window frame so that the

Operating your Skylight Blind.

Use the operating wand, which should have been stipulated for the blinds smooth operation to adjust to the desired level for comfort.